

SH. 1
OF 1

CAT NO

445BZ-12RL

CUSTOMER DIMENSIONS

DO NOT
SEPARATE
PRINT FROM
WORK

LOT NO

OPER

TOOLS

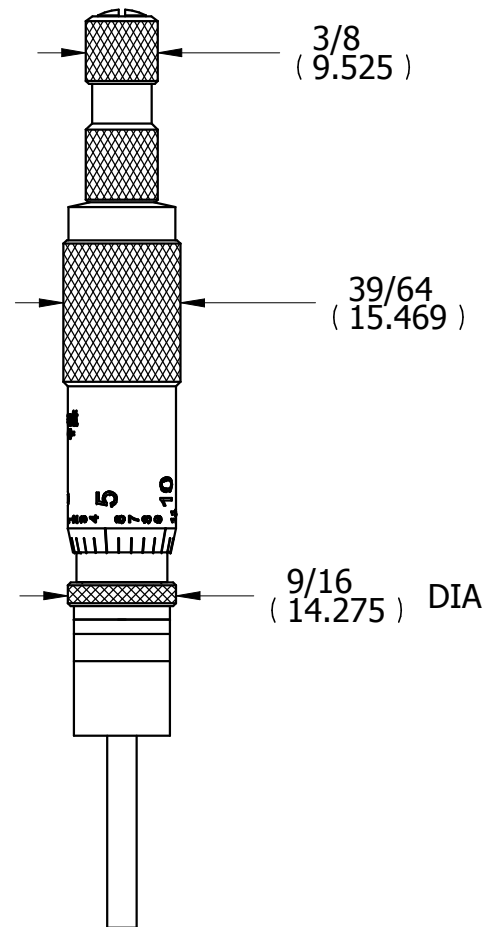
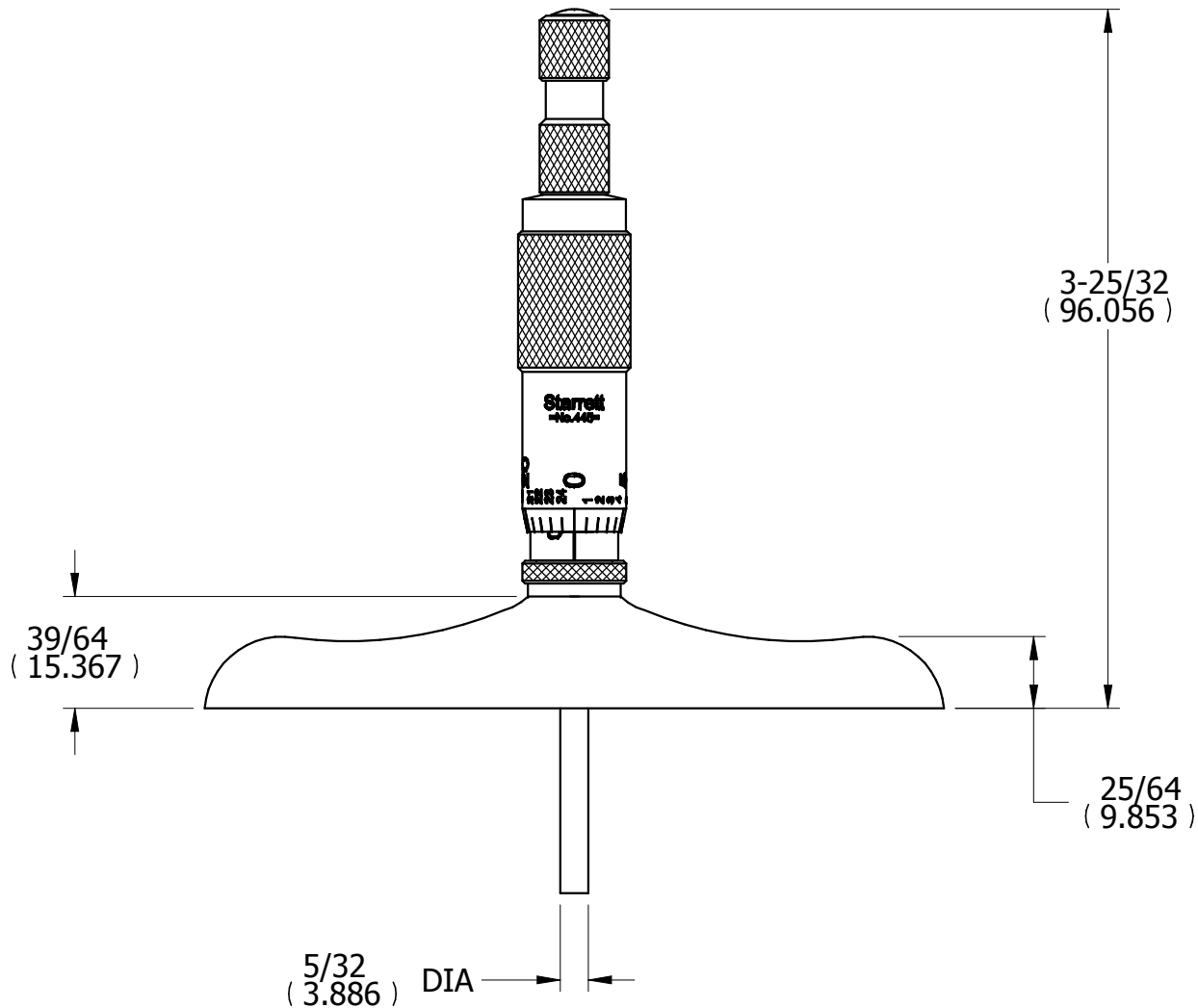
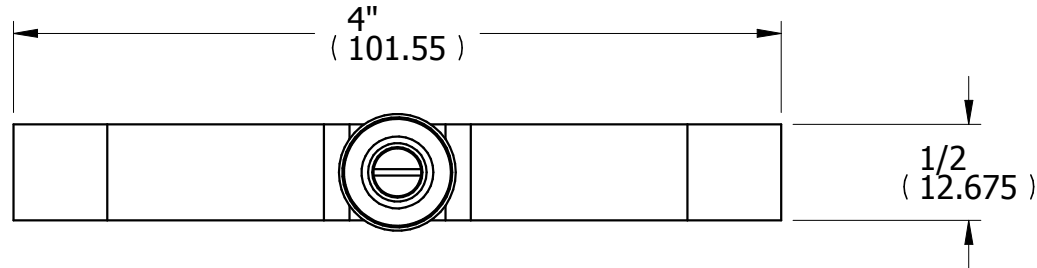

REV	DESCRIPTION	DATE	BY
DR	JAC	CHK	DATE

MICROMETER DEPTH GAGE
ASSEMBLY

TOLERANCES - UNLESS
OTHERWISE SPECIFIED

1 PLACE DEC. or REF. : +/- .015" --- 0.4 mm
2 PLACE DEC. : +/- .010" --- 0.25 mm

3 PLACE DEC. : +/- .003" --- 0.08 mm
4 PLACE DEC. : +/- .0005" --- 0.01 mm

FRACTIONAL: +/- 1/64"
ANGULAR: +/- 1 DEGREE

THE L.S. STARRETT CO.
ATHOL, MASS.